

DNV A60 Linkable Galley Module

CERTIFIED GALLEY FOR SAFE AREAS

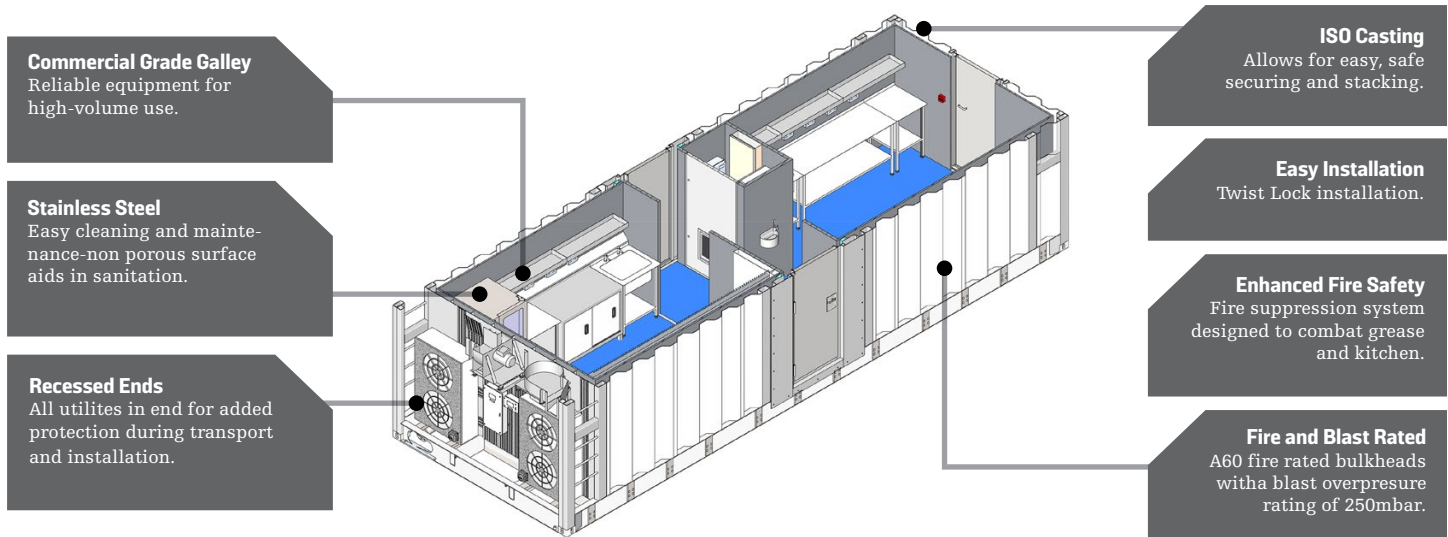

HB Rentals' DNV A60 Galley Modules are designed with the latest equipment. Certified to DNV regulations, the Galley is equipped with stainless steel commercial grade appliances to handle large volumes of output. The Diner can be linked to the Galley for easy in and out access. Unique safety features designed to combat grease fires are standard on the DNV Galleys to ensure fire protection.

Certifications

- DNV 2.7-1
- BS EN 12079

Compliant

- HSE – Notice 82
- MSC/Circ.860
- IMO/SOLAS

Designed for Marine Environments

- DNV 2.7-1 certified – Built to withstand harsh, extreme conditions found in marine environments.
- Structural and lifting components DNV certified.

Purpose Designed

- Stainless steel appliances facilitate cleaning and maintenance- non-porous surface aids in sanitation.
- Commercial grade equipment designed to reliably handle high-volume use over extended periods of time.
- Internal linking corridors mitigate time exposed to outdoor elements.

Flexible Design

- Flexible configuration – Galley & Diner combination can fit up to 50 POB*.
- Linkable design for easy connection between the Galley and Diner without exposing personnel or food to outside elements.
- ISO casting for stacking and securing.

Robust Climate Control

- HVAC system designed for external ambient between -20C° to +50° C.
- Split AC system – each room equipped with individual AC's.
- Isolated HVAC systems allow for individual unit maintenance.

Enhanced Worker Safety Measures

- Enhanced fire suppression system designed specifically to combat grease/kitchen fires.
- A60 fire rated envelope.
- 250mbar blast rated construction.
- Automatic fire dampers.
- Standard Fire & Gas detectors with optional Fire & Gas panel.
- Multiple egress capable – emergency exit hatch in room.

Designed for Safe and Easy Deployment

- Top and bottom ISO casting for stacking and securing.
- Twist lock installation reduces installation time and increases safety.
- Daisy Chain connects consecutive buildings to reduce the number of cable runs required.
- Single side utility connection simplifies installation by reducing cable runs through single side connection.
- Recessed ends housing all utility connections.

Cooking Area

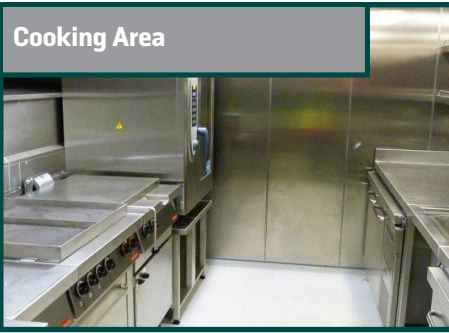

Food Prep Area



Recessed End



Overhead Layout



Specifications

Dimensions/Weight:

9800mm L x 3400mm W x 3050mm H
(32' L x 11' W x 10' H)
18,000kgs
(39,683 lbs.)

Structure:

DNV 2.7-1
BS EN 12079
Includes Lifting Pad Eyes,
Slings, and Shackles

Transportation:

Fitted with ISO Casting

Bulkheads:

Fire Rating: A60

Fire & Gas:

F&G Detection
F&G Panel (Optional)

Fire Damper:

Electro-Mechanical Actuation

Zone Classification:

Safe Area

Power Requirements:

3ph + E
380V-480V, 150amp

Climate Control:

Dual AC's

Design Temperature:

-20° C to +50° C

more info at www.hbrentals.com

Regional Offices

Corporate Headquarters

5813 Highway 90 East
Broussard, LA 70518 USA
Tel +1 337 839 1641
Toll Free 800 262 6790

Americas Corporate Sales

11330 Clay Road
Ste 200
Houston, TX 77041 USA
Tel +1 281 999 0047
Tel +1 281 999 6505
Toll Free 866 999 0040

Europe, Middle East Africa, Asia-Pacific

Howe Moss Drive
Kirkhill Industrial Estate,
Dyce, Aberdeen, AB21 OGL
Tel +44 1224 772304
Fax: +44 1224 772641

Offshore Operating & Service Facilities

Aberdeen, UK

Europe, Middle East, Africa, Asia-Pacific Support

Broussard, USA

Main Operating Facility

Trinidad and Tobago

Ciudad del Carmen, Mexico

Global Markets

Asia-Pacific
Europe
Middle East
Mexico
Trinidad and Tobago
United States/
Canada